

**FUJIFILM**

Always at the primacy of digital imaging  
— the pride and legacy of Fujifilm



FUJI COMPUTED RADIOGRAPHY

**PRIMA** <sup>NEW</sup> Series

<http://www.fujifilm.com/products/medical/>



With the launch of the first FCR (Fuji Computed Radiography) product in 1983, we have brought "DIGITAL" X-ray diagnostics to the world of analog diagnostics. Since then, our products have always been at the forefront of digital imaging and have contributed to improving the efficiency of diagnostic imaging and the quality of medical care. A new stage in the history of X-ray diagnostics has been marked with the announcement of our FCR PRIMA. We are confident that this product will further enhance your diagnostic needs.

Only a pioneer can achieve such a thing  
— Fujifilm's digital imaging system



## Achievement

Since the launching of our first FCR product in 1983, we have been striving to develop the FCR technology further and to make available a wide range of products. Our superb technology and diversified product lineup has gained recognition from medical institutions of all practices and to date over 66,500\* digital imaging systems have been installed worldwide. \* As of end of March 2009

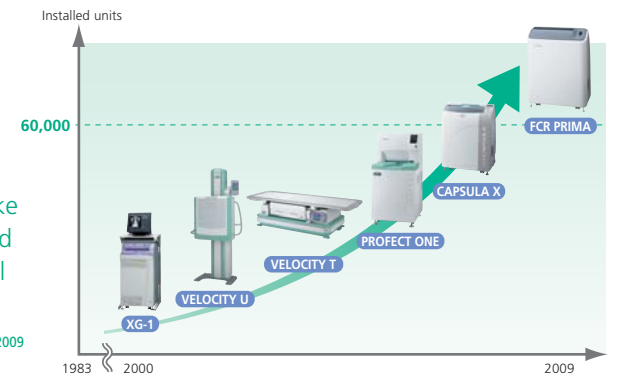

## Quality

We have been able to achieve high imaging quality as a result of our long years of research in the technology of medical imaging. The proven high durability and high stability of our products are proof of our high quality.

### ■ Unparalleled high quality

The FCR offers over 180 pre-set Exposure Menus. They are optimized to each body part and exposure techniques, and supply you with the best quality image without any extra adjustment. Such excellence has been brought about by extensive joint efforts and collaboration with experienced radiologists for over 25 years.

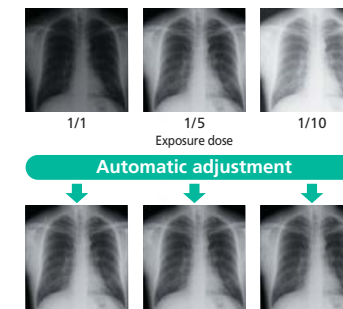

### ■ Durability that we can be proud of

The FCR systems have proven to be day-in and day-out reliable, thanks to the well-designed product features and the built-in redundancy that prevents problems before they occur. In working with the FCR, its proven durability will provide you with the maximum uptime for your medical facilities.

## Originality

Image Intelligence™ from Fujifilm is an integration of various digital image-processing technologies to enhance the contrast and sharpness of the entire image without any risk of losing the image details. As such, Image Intelligence™ is the result of an ideal combination of Fujifilm's many years of experience in imaging and its ability to create superior hardware and software products.



### MFP\* Multi-Frequency Processing

Enhances FCR images. All diagnostic scopes will be enhanced except for noise.  
\*Optional software

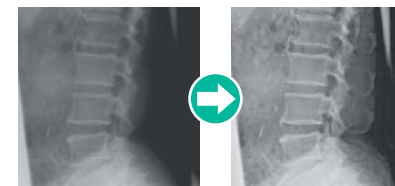

### FNC Flexible Noise Control

Provides a non-grainy image by mainly isolating and suppressing the noise for the signal.

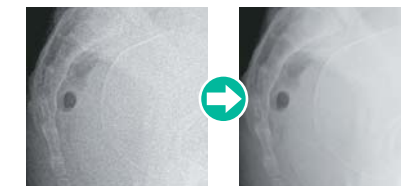

### GPR Grid Pattern Removal

Removes the stationary grid patterns thus preventing Moiré from being generated resulting in easier diagnosis.

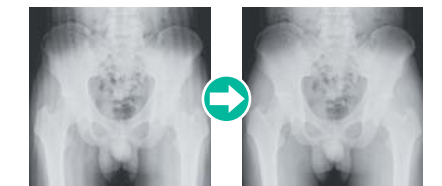

# From digitalize to archive, this is Fujifilm's seamless workflow

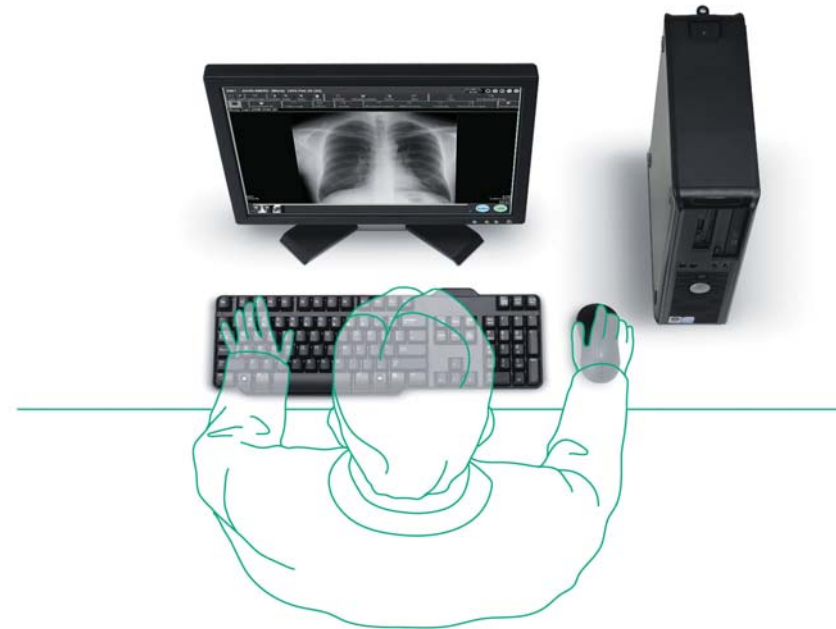
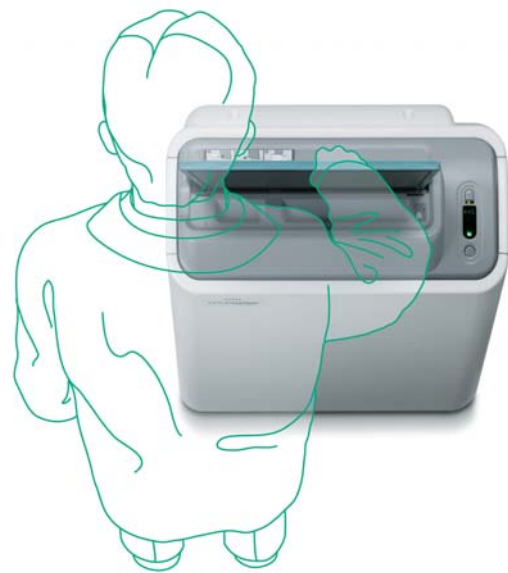

## DIGITALIZE

### Compact footprint, only 0.24m<sup>2</sup>

The FCR PRIMA is one of the most compact and lightweight reader units on the market. The required space is comparatively smaller than other similar table-top systems and can be installed in any open space. Another advantage of this unit is that you don't need a darkroom any longer.



### Flexible reading in various sizes

The IP cassette can read various imaging sizes such as for the chest, lumbar spine, pantomography (15 x 30cm\*), and extremities. Virtually all imaging requirements can be satisfied with a single unit.



\*Optional (To be chosen at the time of purchase)

### Stable and optimized images

Fujifilm's Image Intelligence™ technology automatically enables stable and optimized high-quality images.

### Other features

- Throughput of up to 29 images an hour
- Repeated use of IP

## R E A D

### All-in-one workstation

The FCR PRIMA Console is a complete image management workstation that is designed for simple and fast patient identification, image acquiring and processing, as well as image viewing, reprocessing, optimizing, and archiving.

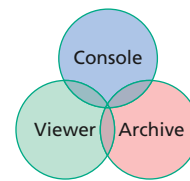

### Quick display with simple operation

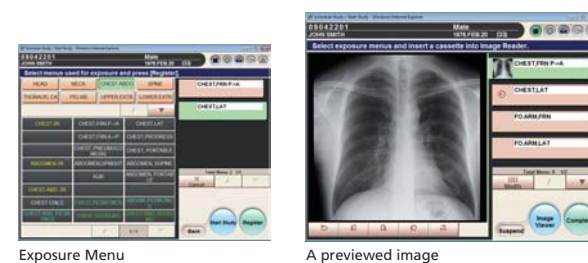

You can customize the user interface according to your preference such as adding shortcut buttons or removing unneeded ones. Just input patient information and select exposure menu, suitable image processing condition will be automatically applied. Adjusted image will be displayed for diagnosis.

### Other features

- Limit of access to patient information for security
- Uses a suitable monitor for medical image display

### Various diagnostic functions

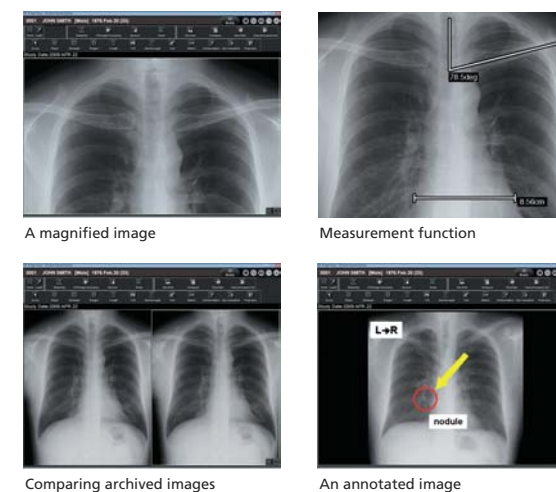

The FCR PRIMA Console is a multi-functional unit that has functions to:

- change the magnification of an image
- display the studied images side-by-side
- compare the latest image with the archived images
- measure the length, angle, etc. of the image
- add annotation text, graphic symbols, and electronic markers to an image

## A R C H I V E

### Integrated management of image data and patient data

You can register a maximum of 200,000 patient data on the PC. The registered patient data can then be speedily retrieved and displayed by entering the patient name and ID number.



### Less storage space

All images are stored in the HDD of the PC. These high-quality images can be copied to a DVD as backup. Requires less storage space than analog imaging systems.



### The PDI (Portable Data for Imaging) function

By bundling the Simplified DICOM Viewer Software with the patient data onto CD-R or DVD-R, images can be distributed to patients for viewing on their PCs.

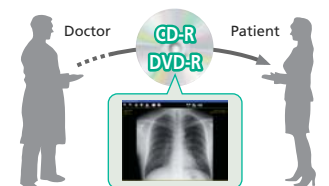

### Other features

- Can send images in JPEG format by e-mail
- Can print film through dry imager

- Preset image processing for more effective diagnosis

## FCR PRIMA Specifications

Standard Components	FCR PRIMA Image Reader (Model: CR-IR 391RU) AC power cord
Other System Components	IP cassette type CC FCR PRIMA Console, FCRView Dry Imager: DRYPIX PRIMA, DRYPIX 2000, 4000, 7000
Supplies	Imaging Plate ST-VI: 35 x 43cm (14" x 17"), 35 x 35cm (14" x 14"), 10" x 12", 8" x 10", 24 x 30cm, 18 x 24cm, 15 x 30cm IP Cassette Type CC: 35 x 43cm (14" x 17"), 35 x 35cm (14" x 14"), 10" x 12", 8" x 10", 24 x 30cm, 18 x 24cm, 15 x 30cm
Time Required for IP Feed/Load	Min. 125 sec.
Processing Capacity	Up to 29 IPs/hr.
Reading Specification	10 pixels/mm
Time to Start on Display	Min. 23 sec.
Time to Print on DRYPIX PRIMA	Approx. 200 sec. in case of 35 x 43cm Approx. 190 sec. in case of 35 x 35cm
Number of Stacker	1
Network	10 Base T/100 Base TX
Dimensions (W x D x H)	600 x 400 x 780mm (24" x 16" x 31")
Weight	70kg (154lbs.)
Power Supply Conditions	Single phase 50-60Hz AC100-240V ±10% 5A (max)
Environmental Conditions	Operating Conditions: <ul style="list-style-type: none"> <li>• Temperature: 15-30°C</li> <li>• Humidity: 15-80%RH (No dew condensation)</li> <li>• Atmospheric pressure: 750-1060hPa</li> </ul>

This equipment is a Class 1 laser product (IEC60825).

**Dimensions**

Unit: mm (in.)

**Imaging Plate ST-VI**

35 x 43cm (14" x 17"),  
35 x 35cm (14" x 14"),  
10" x 12", 8" x 10",  
24 x 30cm, 18 x 24cm,  
15 x 30cm



**IP Cassette Type CC**

35 x 43cm (14" x 17"),  
35 x 35cm (14" x 14"),  
10" x 12", 8" x 10",  
24 x 30cm, 18 x 24cm,  
15 x 30cm





Computed Radiography  
WITH RESPECT TO ELECTRIC SHOCK, FIRE  
AND MECHANICAL HAZARDS ONLY  
IN ACCORDANCE WITH: UL2051/ICAN/CSA C22.2 NO.801.1  
IEC 60601-1 533K

Computed Radiography **CE**  
FCR PRIMA Console CR-IR 391CL **CE** 0123

Specific  
All bran  
In some  
For the

### Dealer Information

A Walsh Imaging, Inc.  
55 Cannonball Road  
Pompton Lakes, NJ 07442

Phone 1-866-429-9729  
Web [www.awalshimaging.com](http://www.awalshimaging.com)

# FUJIFILM

FUJIFILM Corporation

26-30, NISHIAZABU 2-CHOME, MINATO-KU, TOKYO 106-8620, JAPAN  
<http://www.fujifilm.com/products/medical/>