

CR 30-X

Digitizer



- TABLE-TOP DIGITIZER
- BROAD RANGE OF APPLICATIONS
- LOW COST OF OWNERSHIP
- HORIZONTAL CASSETTE INSERTION
- MOBILE



NO QUALITY COMPROMISES

Broad range of applications

CR 30-X is a highly versatile digitizer. It offers an ideal solution for any private and decentralized CR environment. CR 30-X can handle general radiology and dental applications.

Full data

The CR 30-X makes no compromises in image quality: it reads imaging plates at the high resolution of 10 pixels/mm for all image plate sizes.

Table-top

With its table-top size, the CR 30-X digitizer can be placed easily at any location. It works with dedicated cassettes and was designed with ease of use in mind, for optimal handling, comfort and maintenance. When combined with the optionally available universal X-ray shielding, the CR 30-X can be used inside the X-ray room.

Low total cost of ownership

Installing the CR 30-X can be done in a single day. With the special LED technology in the erasure unit, no additional electricity is required, so standard electrical outlets are sufficient. No preliminary electrical work means a lower set-up cost and simpler installation. With its modular, component-based design, it offers faster, easier and more cost-effective maintenance.

NX

CR 30-X is available in combination with NX, Agfa's image identification and quality control tool, for a highly efficient and optimized radiology workflow.

Cassettes with memory

CR 30-X uses dedicated cassettes with an embedded memory that stores the data entered during identification. The built-in antenna card identifies the data by no-touch radiofrequency tagging. ID data and images are linked from the beginning throughout the entire electronic processing system.



CASSETTE SIZES: CR MD4.0T GENERAL CASSETTES

Accepted Cassette Sizes	Spatial Resolution	Pixel Matrix Size
Resolution		
35 x 43 cm (14 x 17")	10 pixels / mm	3480 x 4248
24 x 30 cm	10 pixels / mm	2328 x 2928
18 x 24 cm	10 pixels / mm	1728 x 2328
15 x 30 cm	10 pixels / mm	1440 x 2928

technical

SPECIFICATIONS

GENERAL

Digitizer type

- Single cassette feed
- Throughput:
 - 35 x 43 cm (14 x 17") = approx. 60 plates/hour
 - 24 x 30 cm (9.5 x 12") = approx. 71 plates/hour
 - 18 x 24 cm (7 x 9.5") = approx. 76 plates/hour
 - 15 x 30 cm (6 x 12") = approx. 82 plates/hour

LCD display

- Machine status and error conditions

Greyscale resolution

- Data acquisition: 20 bits/pixel
- Output to processor: 16 bits/pixel

Dimensions and weight

- (W x D x H): 693 x 701 x 464 mm (27.2 x 27.6 x 18.2")
- Depth including input tray: 769 mm (30.3")
- Weight: approx. 98 kg (216.05 lbs)

Power

- 220 - 240 V/50-60 Hz
Standby 120W, max 320W, 16A fuse
- 120V/60Hz (USA)
Standby 120W, max 320W, 15A fuse
- 100V/60Hz (Japan)
Standby 120W, max 320W, 15A fuse

Minimum requirements

- CR MD 4.0T General Cassette
- CR MD 4.0 General Plate
- NX

Environmental conditions

- Temperature: 15 - 30 °C (59 - 86°F)
- Humidity: 15 - 75% RH
- Magnetic fields: max. 3.8 μ T in conformance with EN 61000-4-8: level 2
- Rate of change of temperature: 0.5°C/minute (0.9°F)

Environmental effects

- Noise level: max. 65 dB (A)
- Heat dissipation: standby 120 W, max. 320 W

SAFETY

Approvals

- UL, cUL, CE

Transport details

- Temperature: -25 to +55°C (-4 to 131°F),
-25°C for max. 72 hours, +55°C for max. 96 hours
- Humidity: 5 - 95% RH

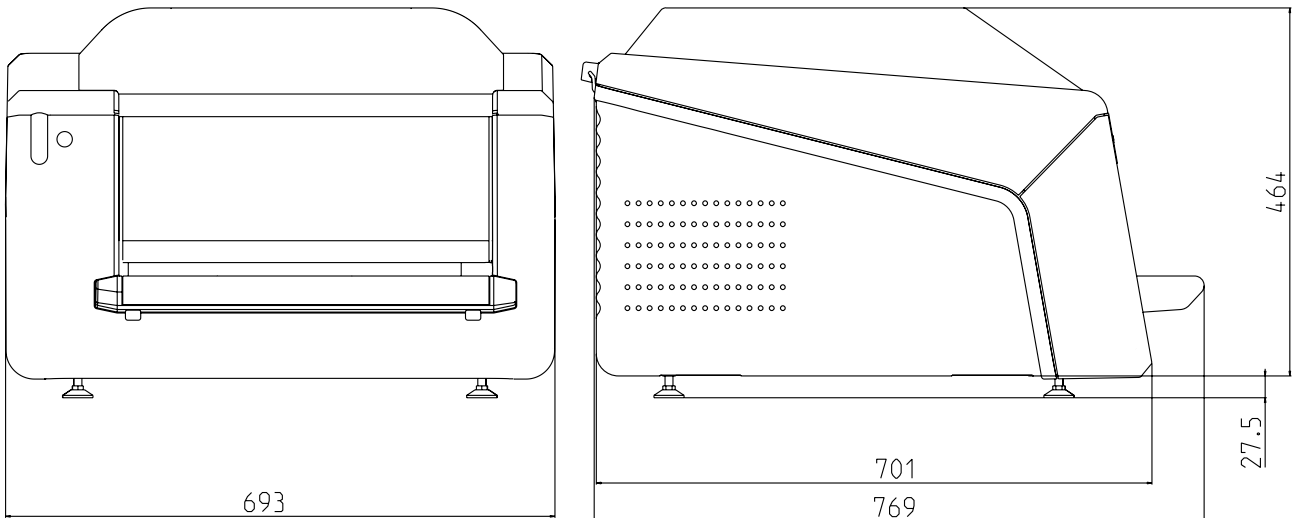

SAFETY

Region	Regulation	X-Ray	Laser
Europe	EN 60601-1: 1990 + A1: 1993 + A2: 1995 EN 60601-1-2: 2001	Regulation: 1987	EN 60825 - 1:2001
USA	UL 60601-1 21CFR part 820: good manufacturing practice for medical devices	DHHS/FDA 21 CFR part 1002, subchapter B	DHHS/FDA 21 CFR parts 1040, 10 and 1040, 11
Canada	CSA22.2 No.601.1 No.601.1.2		



Agfa-Gevaert has been certified by Lloyd's Register Quality Assurance Limited to the following quality management system standard: ISO 9001:2000. The quality management system is applicable to: For Healthcare applications - Marketing, design, development and production of imaging and communication solutions (film, paper and plates, chemicals, components, equipment and software).



Agfa-Gevaert has been awarded the Approval of Conformity certificate by Lloyd's Register Quality Assurance. It certifies that the Quality Management System for our X-Ray films conforms to the requirements of Annex V of the EEC Directive 93/42. Agfa HealthCare has been certified by Lloyd's Register Quality Assurance Limited to the following quality management system standards: ISO 9001:2000 and EN ISO 13485-2003. The quality management system is applicable to: marketing, design, development and production of imaging and communication solutions (film, paper and plates, chemicals, components, equipment and software) for Healthcare applications. Agfa-Gevaert has been awarded the ISO 9001 certificate by TÜV Zertifizierungsgemeinschaft e.V. This is applicable to Agfa's Quality Management System for design, production and servicing of Agfa Medical Equipment. Products distributed in North America are manufactured by/for Agfa Corporation, 10 South Academy St., Greenville, South Carolina 29601. Agfa, the Agfa rhombus and MUSICA are trademarks of Agfa-Gevaert N.V., Belgium or its affiliates. All other trademarks are held by their respective owners and are used in an editorial fashion with no intention of infringement. The data in this publication are for illustration purposes only and do not necessarily represent standards or specifications which must be met by Agfa. All information contained herein is intended for guidance purposes only, and characteristics of the products described in this publication can be changed at any time without notice. Products may not be available for your local area. Please contact your local sales representative for availability information. Agfa diligently strives to provide as accurate information as possible, but shall not be responsible for any typographical error.

Agfa Corporation

HealthCare Headquarters
10 South Academy Street,
Greenville, SC 29601

Canada

Agfa, Inc.
77 Belfield Road, Etobicoke, Ont.,
M9W 1G6

Mexico

Agfa de México, S.A. de C.V.
Benjamin Franklin #98, Colonia
Escandon, C.P. 11800, México, D.F.